

➤ 24 SAAT TEKNİK SERVİS

➤ YEDEK PARÇA GARANTİSİ

➤ ISO 9001 ONAYI

➤ YÜKSEK KAPASİTE

➤ YERDEN TASARRUF



Üniversite Mah. Bağlar Mevkii Sangül Sok.No:6/A Avcılar / İstanbul  
Tel: 0212 694 77 88 Fax: 0212 694 77 22  
E.mail : dogrusoz@dogrusoz.com

www.dogrusoz.com



**quick** Filling Machine  
**quick** Dolum Makinası







## Monoblok Dolum Makinası

### Modeller

Quick Modeller	Çalkalama Kafası	Dolum Nozulu	Kapatma Kafası
Quick 5000	16	16	6
Quick 12000	24	24	8
Quick 18000	36	36	12
Quick 24000	48	48	16

### Kapasite

Quick Modeller	Şişe/Saat 1.5L	Şişe/Saat 0.5L
Quick 5000	5000	6500
Quick 12000	9000	12000
Quick 18000	14000	18000
Quick 24000	18000	24000

### Makina Özellikleri

- › Çalışma sistemi : Rotatif
- › Şase tipi : Monoblok gövde çalkalama-dolum-kapatma
- › Dolum sistemi : Seviye dolum sistemi,dolum süresince hiçbir parça birbirine temas etmez.
- › 0.5-1.5L değişim süresi : 5dk
- › Şişe taşıma sistemi : Komple boyundan taşıma
- › Şişe yok - Çalkalama yok prensibi
- › Şişe yok - Dolum yok prensibi
- › Şişe yok - Kapatma yok prensibi
- › Otomatik kapak lokma boşaltma sistemi
- › Kapak kapatma sistemi : Tut ve Kapa
- › Kapatma fafaları : Magnetik tork ayarlı
- › Kapak dizme : Pnömatik tuzaklı rotatif sistem
- › Kapak besleme : Otomatik elevatör
- › Elevatör kapasitesi : 5000 kapak
- › Malzeme : Komple 316 Cr-Ni



## Monoblok Filling Machine

### Specifications

Quick Modeller	Rinsing Head	Filling Nozzle	Capping Head
Quick 5000	16	16	6
Quick 12000	24	24	8
Quick 18000	36	36	12
Quick 24000	48	48	16

### Capacity

Quick Modeller	Bottle/Hour1.5 L	Bottle/Hour0.5 L
Quick 5000	5000	6500
Quick 12000	9000	12000
Quick 18000	14000	18000
Quick 24000	18000	24000

### Properties of Machine

- › Operating system : Rotary
- › Chassis type : Monoblock Rinser-Filler-Capper
- › Filling system : Gravity filling system
- › 0.5-1.5 L change-over time : 5 min
- › Bottle handling system :Complete Neck-andling
- › No bottle-No Washing principle
- › No bottle-No Filling principle
- › No bottle-No Cap principle
- › Automatic cap ejection system
- › Capping system : Pick & Place
- › Capping heads : Adjustable magnetic torque
- › Cap feeding : Automatic elevator
- › Cap way feeding : With pnomatik trap,rotary system
- › Elevator capacity: 5000 caps
- › Material : Complete 316 Cr-Ni

quick





# Bobinden Beslemeli Etiketleme Makinası

# Roll-fed Labelling Machine



## Specifications

Main Drum	Capacity	Bottle Size		Label Length	
		Min	Max	Min	Max
420/3P	12000-18000bph	50 mm	120 mm	150 mm	385 mm
420/4P	15000-24000bph	40 mm	85 mm	135 mm	275 mm

## Properties of Machine

- › Label driving System: Servo Motor
- › Main motor : 1.5 kW
- › Operating Temperature: 10-40 C
- › Glue type : hot-melt
- › Entry station starwheel : Existing/According to the bottle desing
- › Entry auger: Existing/According to the bottle desing
- › Entry starwheel : Existing/According to the bottle desing
- › Exit starwheel : Existing/According to the bottle desing
- › Roll tension stabilization: Electronic pad
- › 0.5 - 1.5 L Air setting changing : With a single button from operator
- › 0.5 - 1.5 L height of roll changing :With a single main point
- › Label length control:Active as long as the machine is running
- › Reset while changing roll: With a single button from operator pannel
- › Protection : Complete transparency can be seen from all directions

# RF18000

## Özellikler

Ana Tambur	Kapasite	Şişe Ölçüsü		Etiket Boyu	
420/3P	12000-18000bph	Min 50 mm	Max 120 mm	Min 150 mm	Max 385 mm
420/4P	15000-24000bph	Min 40 mm	Max 85 mm	Min 135 mm	Max 275 mm

## Makina Özellikleri

- › Etiket Sürme Sistemi :Servo Motor
- › Ana Motor :1.5 kW
- › Çalışma Sıcaklığı : 10-40C
- › Tutkal Cinsi :Sıcak tutkal
- › Giriş durak tepsi : Mevcut / Şişeye göre tasarlanmış
- › Giriş burgusu : Mevcut / Şişeye göre tasarlanmış
- › Giriş tepsi : Mevcut / Şişeye göre tasarlanmış
- › Çıkış Tepsi :Mevcut / Şişeye göre tasarlanmış
- › Bobin gerginlik sabitleme :Elektronik balata
- › 0.5 - 1.5 L hava değişim : Operatör panelinden tek tuş
- › 0.5 - 1.5 L bobin yükseklik ayarı : Tek noktadan bobinin yürüdüğü tablanın yüksekliğini
- › Etiket uzunluğu kontrol :Makine çalıştığı sürece etiket uzunluğu kontrol sistemi
- › Bobin değişiminde sıfırlama :Kontrol panelinden tek tuş ile sıfırlama yapabile
- › Muhafaza :Komple her yönden görülebilen şeffaf muhafaza







- > 24 SAAT TEKNİK SERVİS
- > YEDEK PARÇA GARANTİSİ
- > ISO 9001 ONAYI
- > YÜKSEK KAPASİTE
- > YERDEN TASARRUF

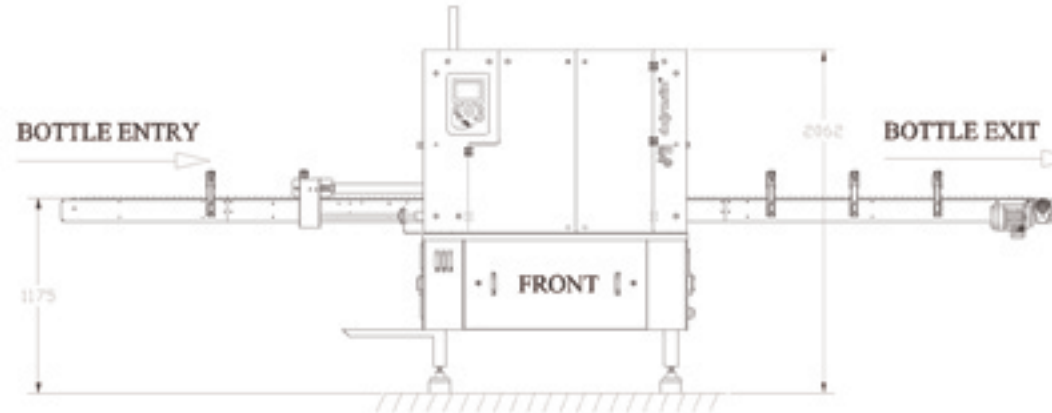
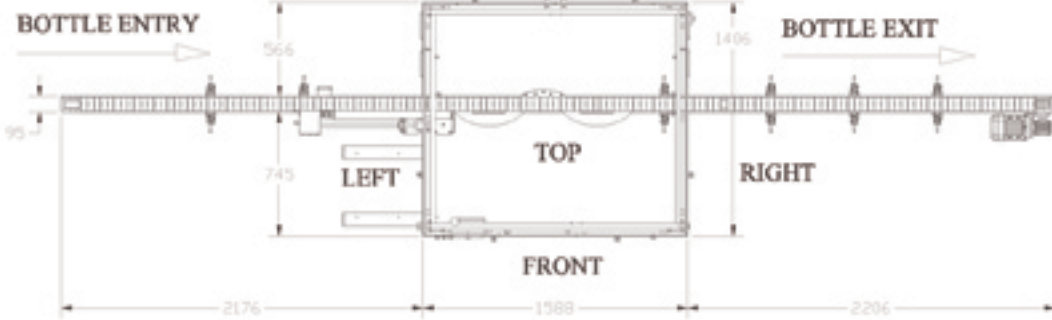

**doğrusöz  
makina**

Üniversite Mah. Bağlar Mevkii Sarıgül Sok.No:6/A Avcılar / İstanbul  
Tel: 0212 694 77 88 Fax: 0212 694 77 22  
E.mail : dogrusoz@dogrusoz.com

www.dogrusoz.com



**RF18000** Roll-fed Labelling Machine

**RF18000** Bobinden Beslemeli Etiketleme Makinası

